

PureFlow® Bronze Zero Lead PEX Press Fittings with Attached Stainless Steel Press Sleeves for ViegaPEX™, ViegaPEX™ Ultra, ViegaPEX™ Barrier and FostaPEX® SDR-9 Cross-linked Polyethylene (PEX)

Scope

This product specification designates the requirements for PureFlow bronze zero lead PEX Press fittings with attached stainless steel press sleeves and tool locator ring to be used as connections for ViegaPEX, ViegaPEX Ultra, ViegaPEX Barrier, and FostaPEX tubing in 5/16", 3/8", 1/2", 5/8", 3/4", 1", 1-1/4", 1-1/2" and 2" sizes as available. The connections are to be completed with the aid of a PureFlow PEX Press Hand Tool or PureFlow PEX Press Power Tool.

Materials

PureFlow bronze zero lead PEX Press fittings are cast and machined from extruded (C87700) or forged (C87710) zero lead bronze. This gives the fitting high-corrosion and stress-crack resistance. All PureFlow bronze zero lead PEX Press fittings are precision-made to tight tolerances for a consistent fit with ViegaPEX tubing. All bronze zero lead PureFlow PEX Press fittings meet the rigorous requirements of ANSI/NSF-61 Annex G for lead extraction and meet California AB 1953 no lead requirements. "Zero Lead" identifies Viega products meeting the lead free requirements of California and Vermont law, effective January 1, 2010, as tested and listed against NSF-61, Annex G.

The stainless steel press sleeves incorporate three (3) view holes and are manufactured from 304 stainless steel that will not corrode, maintaining a clean appearance for the lifetime of the system. The tool locator rings are color-coded to match their appropriately sized PEX Press hand tools and are manufactured out of recycled plastic. (Stainless steel locator rings are used for solder adapters.)

Marking and Certification

PureFlow bronze zero lead PEX Press fittings with attached stainless steel sleeves are manufactured and certified to the requirements of ASTM F877. PureFlow bronze zero lead PEX Press fittings and sleeves are marked with the size, manufacturer's mark and required marking(s) of third-party certification organizations. Fittings also meet the requirements of ANSI/NSF-61 Annex G for health effects and are suitable for contact with potable water. NSF International and other certification organizations conduct random on-site inspections of manufacturing facilities and independently test PureFlow bronze zero lead PEX Press fittings for compliance with physical, performance and toxicological standards.

Recommended Uses

PureFlow bronze zero lead PEX Press fittings with attached stainless steel press sleeves are intended and recommended for use in potable water distribution systems with ViegaPEX, ViegaPEX Ultra and FostaPEX tubing, and for hydronic heating, snow melt and cooling systems with ViegaPEX Barrier and FostaPEX tubing meeting the requirements of ASTM F876 and multipurpose residential fire sprinkler systems per NFPA 13D with ViegaPEX Ultra Black (sizes 3/4" to 1-1/2") meeting the requirements of ASTM F876 and UL 1821 (130 psi @ 120°F). Maximum design temperature and pressure ratings are 160 psi @ 73°F, 100 psi @ 180°F and 80 psi @ 200°F. PureFlow bronze zero lead PEX Press fitting system components are available only from Viega and are not interchangeable with components and tubing from other suppliers. For information on other hot and cold applications not listed here, consult with your Viega representative.

Handling and Installation

PureFlow bronze zero lead PEX Press fittings are cast and machined from a solid bronze alloy and precision-made to tight tolerances. Use of these materials in hot and cold water distribution systems must be in accordance with good plumbing practices, applicable code requirements, and current installation practices available from Viega. Contact a Viega representative or the applicable code enforcement bureau for information about approvals for specific applications.

Viega... The global leader in plumbing and heating systems.

301 N. Main, 9th Floor • Wichita, KS 67202 • Ph: 800-976-9819 • Fax: 800-976-9817 • E-Mail: insidesales@viega.com • www.viega.com

Quality Assurance

When the product is marked with the ASTM F877 designation, it affirms that the product was manufactured, inspected, sampled and tested in accordance with these specifications and has been found to meet the specified requirements.

Certifications

cNSF®us pw-G

- Zero lead listing meeting California AB 1953 and Vermont ACT 193
- NSF International Performance and Health Effects (Standards 14 & 61)
- NSF certified to CSA B137.5 (Canadian Standards Association)

NSF Certified to NSF-U.P. Code

- approved for Uniform Plumbing Code, listed to ASTM F877



- IAPMO Certified



- ANSI/NSF 61-G



- ICC ES-PMG™ 1038/1015 plumbing and heating systems



- UL certified to UL 1821 listing (130 psi @ 120°F) for use in multipurpose residential fire sprinkler systems per NFPA 13D.¹

Note: all fittings may not be listed with each organization shown.

Friction Loss

PureFlow Bronze Zero Lead PEX Press Fittings

(Equivalent Length of Tubing in Feet)

SIZE	COUPLING	90° ELBOW	TEE RUN	TEE BRANCH
3/8"	2.9	9.2	2.9	9.4
1/2"	2	9.4	2.2	10.4
3/4"	1	8	1	9
1"	1	10	2	10
1-1/4"	2	11	2	11
1-1/2"	2	13	2	12
2"	2.3	19	3.3	18.3

This information is based on tubing nominal flow rate.
(@ 8 fps flow velocity)

- 3/4" through 1-1/2" fittings only
- Tool locator rings must be left on the fitting in their factory assembled orientation (as shown above) prior to making a proper PEX Press connection. Press connections made with the tool locator ring removed or in the wrong orientation may result in an incorrect press.

PureFlow Bronze Zero Lead PEX Press Fittings Typical Fitting Insert Dimensions

SIZE	A	B	L
5/16"	0.169	0.281±.002	0.496
3/8"	0.236	0.344±.002	0.496
1/2"	0.362	0.473±.002	0.496
5/8"	0.457	0.571±.002	0.496
3/4"	0.559	0.667±.003	0.496
1"	0.728	0.858±.004	0.618
1-1/4"	0.957	1.047±.004	0.866
1-1/2"	1.083	1.232±.004	0.866
2"	1.417	1.606±.004	1.260

NOTE: Dimensions are in English units. Tolerances shown are Viega requirements. Viega Bronze Zero Lead PEX Press fittings are manufactured within these specifications.

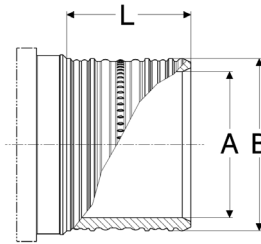

(number of ribs may vary per fitting size)

Attached Stainless Sleeve, Pressed

A pressed fitting has jaw witness marks (P) indicating the connection has been properly made.

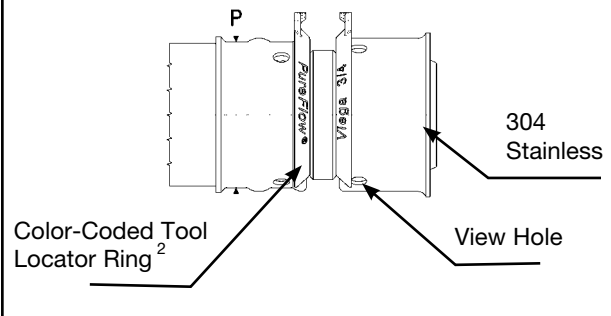

Viega... The global leader in plumbing and heating systems.

301 N. Main, 9th Floor • Wichita, KS 67202 • Ph: 800-976-9819 • Fax: 800-976-9817 • E-Mail: insidesales@viega.com • www.viega.com